

REV.
E

AS1718™

RATIONALE

CORRECT THE DRAFTING ERROR OF $.500 \pm .015$ DIMENSION IN SECTION A-A. ADD GENERAL NOTE 14.
CORRECT ANGULAR TOLERANCE ERROR IN NOTE 8.

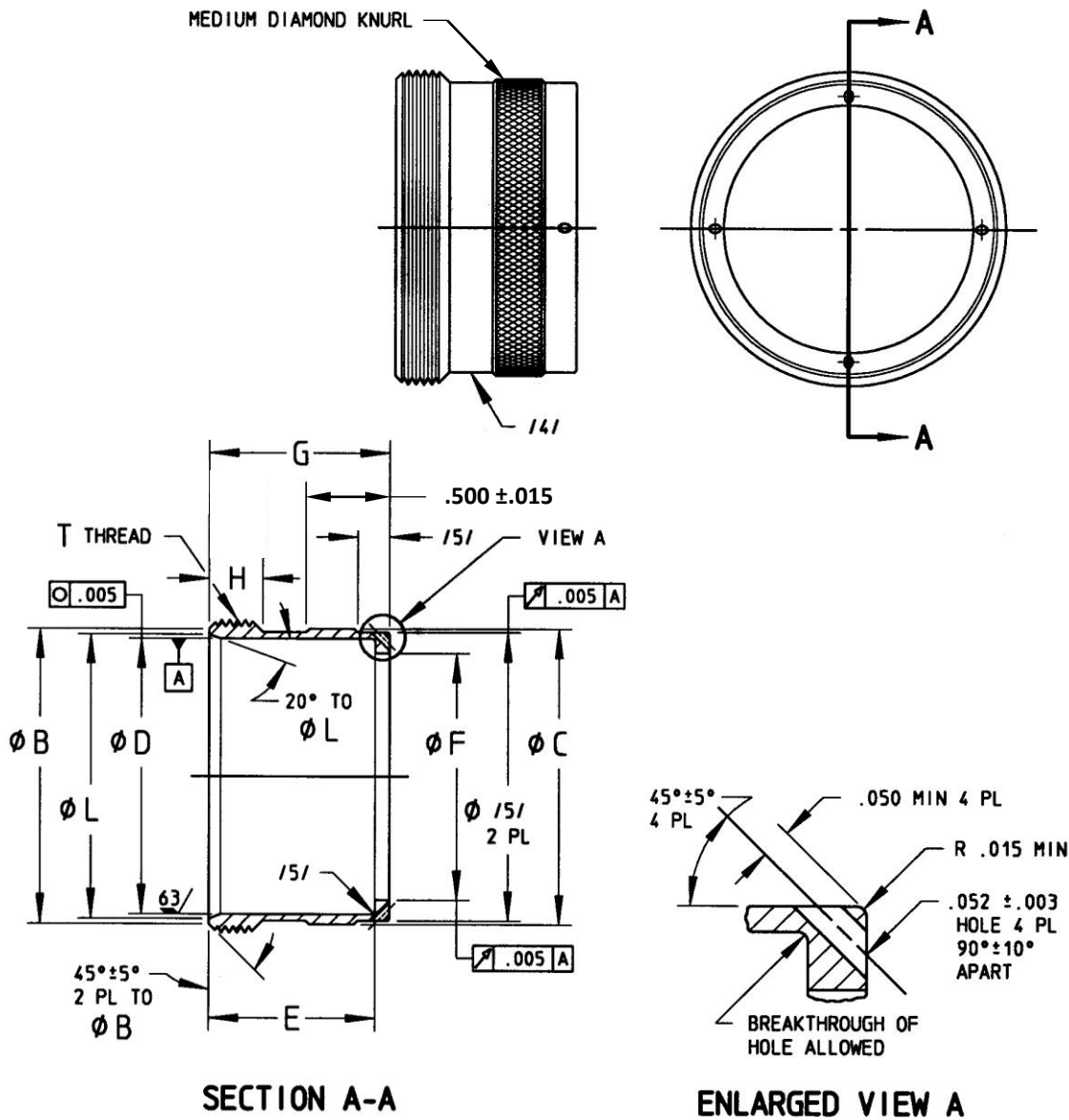
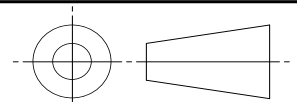

FIGURE 1 - BODY

SAE values your input. To provide feedback on this Technical Report, please visit <http://www.sae.org/technical/standards/AS1718E>

THIRD ANGLE PROJECTION



CUSTODIAN: G-3/G-3A

PROCUREMENT SPECIFICATION: AS1710, SEE NOTE 3



AEROSPACE STANDARD

COUPLING BODY, FLEXIBLE,
VARIABLE CAVITY, THREADED
FERRULE TYPE TUBE ENDS

AS1718™
SHEET 1 OF 3

REV.
E

SAE Technical Standards Board Rules provide that: "This report is published by SAE to advance the state of technical and engineering sciences. The use of this report is entirely voluntary, and its applicability and suitability for any particular use, including any patent infringement arising therefrom, is the sole responsibility of the user." SAE reviews each technical report at least every five years at which time it may be revised, reaffirmed, stabilized, or cancelled. SAE invites your written comments and suggestions.